

NEW Wet Type Solenoid Valves

SS/SA SERIES G01-40 DESIGN

This valve contributes to equipment energy saving while maintaining a maximum pressure of 35MPa and maximum flow of 100ℓ/min

Characteristics

- **Reduced electricity consumption of 19.8W***
(25% reduction from previous model)
- **Reduced coil surface temperature of approx. 30°C**
(after continuous power comparing with previous model)
- **Toolless wiring connection is possible**
(M12-4 pin connector terminal box option available)
- **CE, UL,cUL Approval**

*:For DC24V

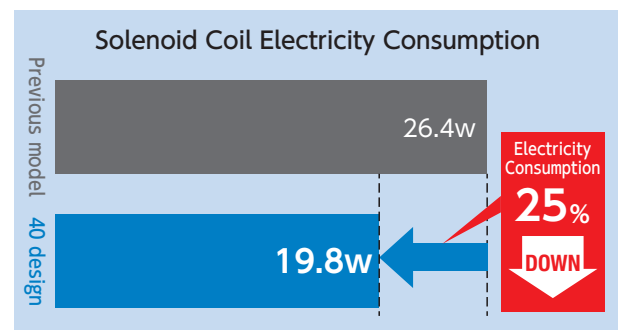

M12-4 Pin Connector

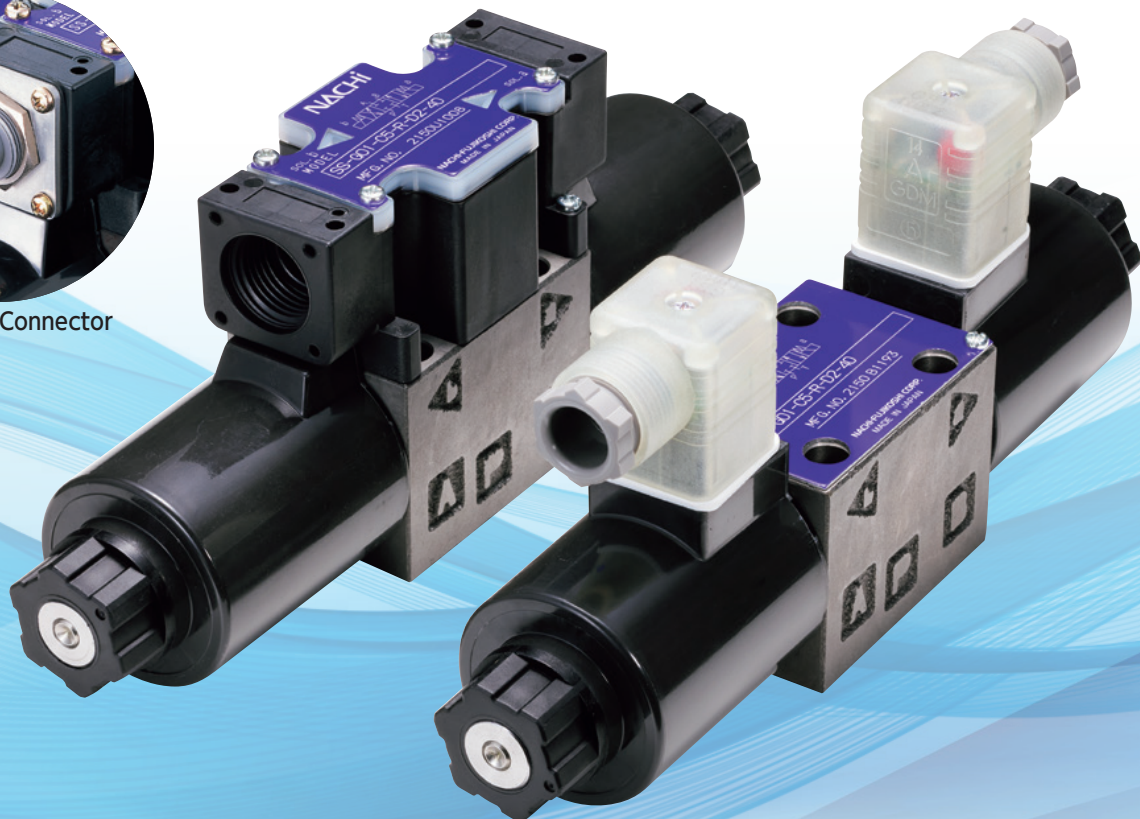

SS/SA SERIES G01-40 DESIGN

Main Specs

Item	SS/SA-G01-40*1
Max. Working Pressure (P, A, B port)	35MPa
Max. flow*2	100 ℓ/min
Allowable back pressure (T port)	21MPa
Oversea Safety Regulation	CE, UL, cUL
Gasket Surface Dimension	ISO 4401-03-02-0-05

*1:DC type (DC, DC with built-in rectifier) solenoid valve will change to 40 design. AC type solenoid valve will not change and stay as 31 design.
*2:Max flow will be different depends on spool configuration or working pressure.

Solenoid Valve Specs

Category	Power Supply Type	40 design				
		Voltage (V)	Frequency (Hz)	Holding Current (A)	Holding Power (W)	Allowable Voltage range (V)
DC	D1	DC12	—	1.63	19.5	10.8~13.2
	D2	DC24	—	0.83	19.8	21.6~26.4
DC with Built-in Rectifier	E1	AC100	50/60	0.23	20.0	90~110
	E115	AC115	50/60	0.21	21.8	100~125
	E2	AC200	50/60	0.12	20.7	180~220
	E230	AC230	50/60	0.11	21.9	200~250

Installation Dimension Drawings

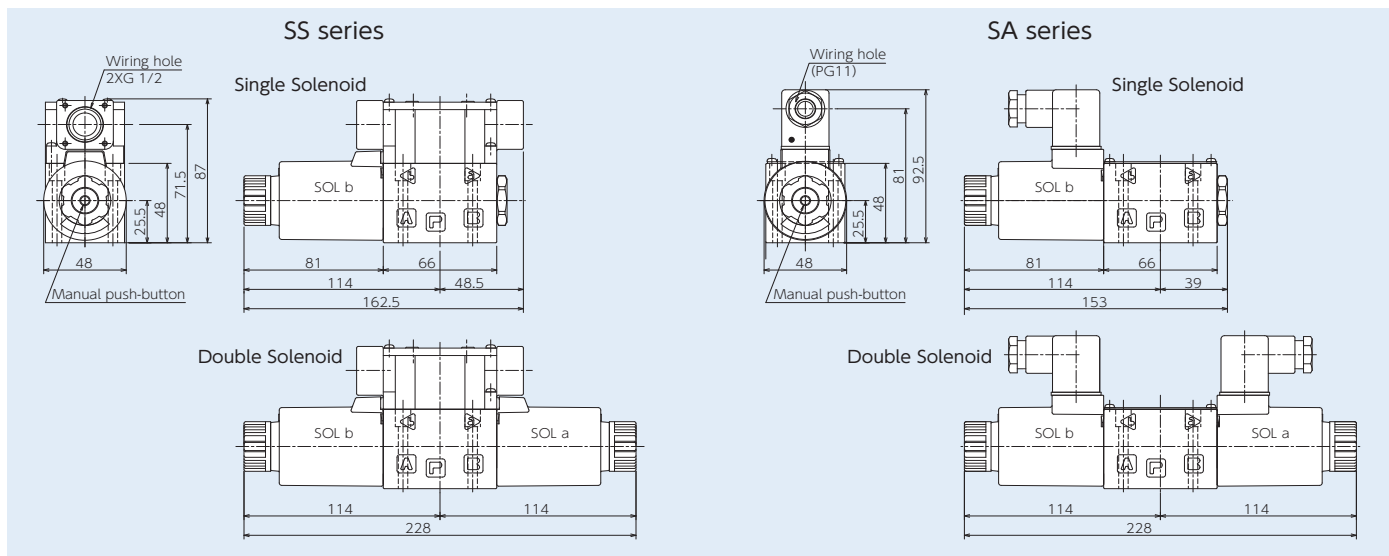

NACHI
NACHI-FUJIKOSHI CORP.

<http://www.nachi.com/>

Head Office Shiodome Sumitomo Bldg. 17F, 1-9-2 Higashi-Shinbashi, Minato-ku, Tokyo 105-0021 TEL:+81-(0)3-5568-5240 FAX:+81-(0)3-5568-5236

NACHI AMERICA INC. HEAD QUARTERS	Indiana, U.S.A.	TEL:+1-317-530-1001	FAX:+1-317-530-1011	http://www.nachiamerica.com/
NACHI EUROPE GmbH	GERMANY	TEL:+49-(0)2151-65046-0	FAX:+49-(0)2151-65046-90	http://www.nachi.de/
NACHI TECHNOLOGY (THAILAND) CO., LTD.	THAILAND	TEL:+66-2-714-0008	FAX:+66-2-714-0740	http://www.nachi.co.th/
NACHI SINGAPORE PTE. LTD.	SINGAPORE	TEL:+65-65587393	FAX:+65-65587371	http://www.nachinip.com.sg/
FUJIKOSHI-NACHI (MALAYSIA) SDN. BHD.	MALAYSIA	TEL:+60-(0)3-80247900	FAX:+60-(0)3-80235884	
NACHI-FUJIKOSHI (CHINA) CO., LTD.	CHINA	TEL:+86-(0)21-6915-2200	FAX:+86-(0)21-6915-5427	https://www.nachi.com.cn/

• Pump specifications are subject to change without notice for improvement.

• Copying of this document, and giving it to others and the use or communication of the contents thereof, are forbidden without express authority.

CATALOG NO. H9418E

2023.07.*.ABE-ABE