

# Sealed SKF Explorer spherical roller bearings

Protected for superior field performance

A large, detailed 3D rendering of a spherical roller bearing is the central focus of the image. The bearing is shown in a cutaway view, revealing its internal structure: two outer rings with spherical inner surfaces, and several spherical rollers held in place by a cage. The metal surfaces are highly reflective, showing highlights and shadows that emphasize their curved geometry. The background is a clean, light blue gradient, which makes the metallic bearing stand out prominently.

*Now with improved performance  
of small sealed spherical roller  
bearings*



# Superior protection for longer



When SKF invented the spherical roller bearing in 1919, it opened a new world of possibilities for industrial applications. The self-aligning capabilities of this breakthrough design enabled longer bearing life in the most demanding applications.

With the introduction of sealed spherical roller bearings, service life in contaminated environments can be significantly increased. Pre-lubricated with a specially formulated grease and sealed with highly effective contact seals, these bearings can in many applications be considered lubricated for the life of the bearing. By eliminating or extending relubrication intervals, sealed SKF spherical roller bearings can significantly reduce the costs to purchase, apply and dispose of grease.

## Benefits include:

- Significantly increased uptime
- Substantially reduced need for maintenance
- Reduced grease consumption and disposal cost
- Less environmental impact
- Improved worker safety



# life and reduced maintenance



## Up to four times the rating life of open bearings

In a typically contaminated environment, a sealed bearing has a rating life of up to four times that with an open bearing. Longer service life leads to more productive and profitable operation.

## SKF EnCompass Field Performance Programme: theory meets reality

One might think that two bearings of the same size with the same dynamic load rating should perform equally well in a given application. In reality, they often do not. The reason?

Bearing performance under actual operating conditions is impacted by not only the dynamic load rating (C), but far more by the bearing's inherent design and quality: everything from the surface finish of the raceways to the effectiveness of sealing and lubrication.

The SKF EnCompass Field Performance Programme addresses this issue. By focusing on bearing design optimization and more detailed analysis of the factors influencing bearing service life, the programme will help to meet real-world application conditions.

At the heart of SKF EnCompass are new, more inclusive bearing life models, including the SKF Generalized Bearing Life Model, which separates sub-surface and surface failure modes. By encompassing more of the factors that impact bearing service life, this model and new software tools provide new insight into the calculation of bearing rating life. The result is a significantly improved guide for selecting bearings for optimum reliability and productivity in the field.

As part of the SKF EnCompass programme, sealed SKF spherical roller bearings have been optimized to give you a field advantage.

# Small sealed SKF spherical roller bearings

## Less maintenance, longer life

Sealed SKF Explorer spherical roller bearings can significantly increase bearing service life in contaminated environments. These bearings are pre-lubricated with a specially formulated grease and sealed with highly effective contact seals. The seals protect the bearing and lubricant from contaminants that might otherwise cause premature bearing failure.

In many applications, these bearings can be considered lubricated for the life of the bearing. By eliminating or extending relubrication intervals, these bearings can significantly reduce the cost to purchase, apply and dispose of grease. Reduced maintenance costs will, in many cases, substantially reduce the total cost of ownership of an application.

## Half the friction, twice the speed

With a new design that results in up to 50% less seal friction, SKF's small sealed spherical roller bearings (shown in blue colour in **diagram 1**) reduce operating temperatures by as much as 20 °C (36 °F) (→ **diagram 2**), enabling us to double the limiting speed rating. As a result, more applications can benefit from the superior contamination protection of sealed SKF spherical roller bearings.

Sealed spherical roller bearings are suitable for a wide range of applications including elevators, off-highway and agricultural machinery, fans and fluid machinery, food and beverage equipment, conveyors and some small electric motors.





## Additional benefits:

- Total bearing friction reduced by as much as 20%
- Relubrication intervals can be up to twice as long
- Grease usage can be reduced significantly
- In many applications the bearing can be considered relubrication-free for the life of the bearing, reducing maintenance costs

Diagram 1

Sealed SKF spherical roller bearing range

d [mm]	Series								Size	
	213	222	223	230	231	232	239	240		241
25		↔								05
30		↔								06
35		↔								07
40		↔	↔							08
45		↔	↔							09
50		↔	↔							10
55		↔	↔							11
60		↔	↔							12
65		↔	↔							13
70		↔	↔							14
75		↔	↔							15
80		↔	↔							16
85		↔								17
90		↔	↔							18
95		↔								19
100		↔								20
110		↔								22
120		↔								24
130		↔								26
140										28
150										30
160										32
170										34
180										36
190										38
200										40
220										44
240										48
260										52
280										56
300										60
320										64
340										68
360							1)			72
380										76
400										80
420							1)			84
440										88
460							1)			92

-  = Open spherical roller bearings available
-  = Open and sealed spherical roller bearings available, designation suffix 2CS
-  = Open and sealed spherical roller bearings available, designation suffix 2RS
-  ↔ Sealed bearing is slightly wider than open bearing

<sup>1)</sup> Can be delivered with some restrictions, please contact your sales representative.

# Bearings with improved performance

## Sealed SKF spherical roller bearing with designation suffix RS

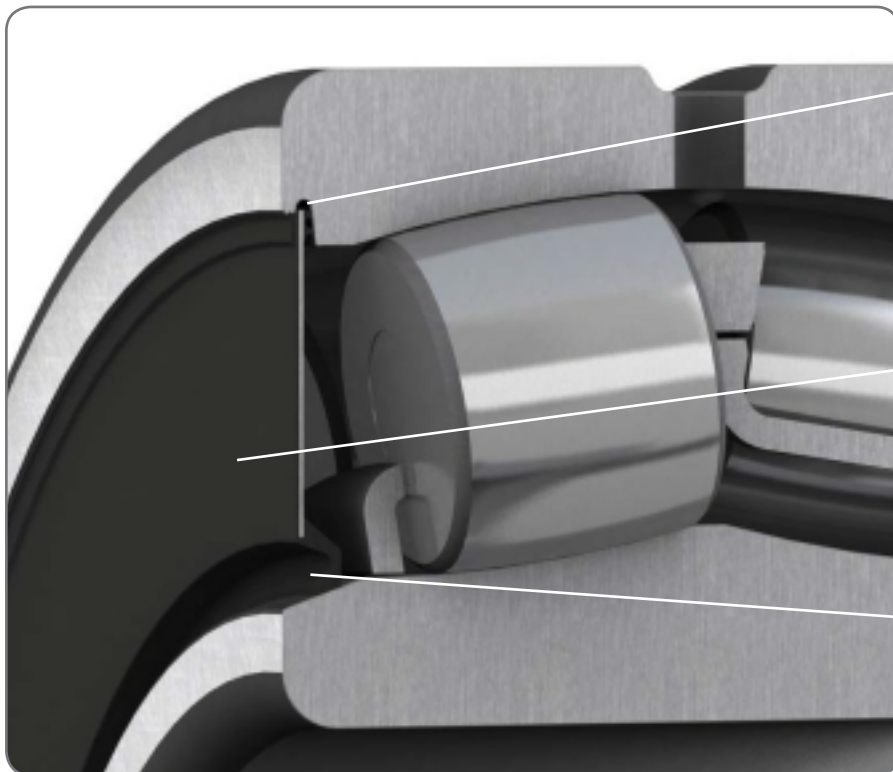

New seal groove design to improve seal anchorage for a better fit

Rubberized side face, more resistant to scratches and corrosion

New seal lip with optimized seal lip pressure – reducing seal friction by up to 50%

Diagram 2

### Sealed SKF spherical roller bearing operating temperature

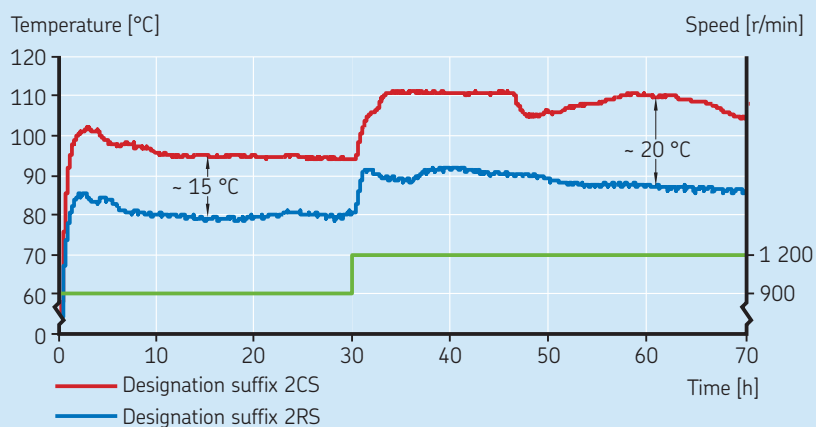

### Test conditions:

Bearings: 23022-2CS/VT143 and 23022-2RS/VT143

Load:  $C/P = 10$ , pure radial load

Speed: 900 r/min and 1 200 r/min

Temperature measured on outer ring

The reduced seal friction of the bearings with improved performance (designation suffix RS) results in lower operating temperature, enabling extended relubrication intervals.

# Protecting bearings and profits

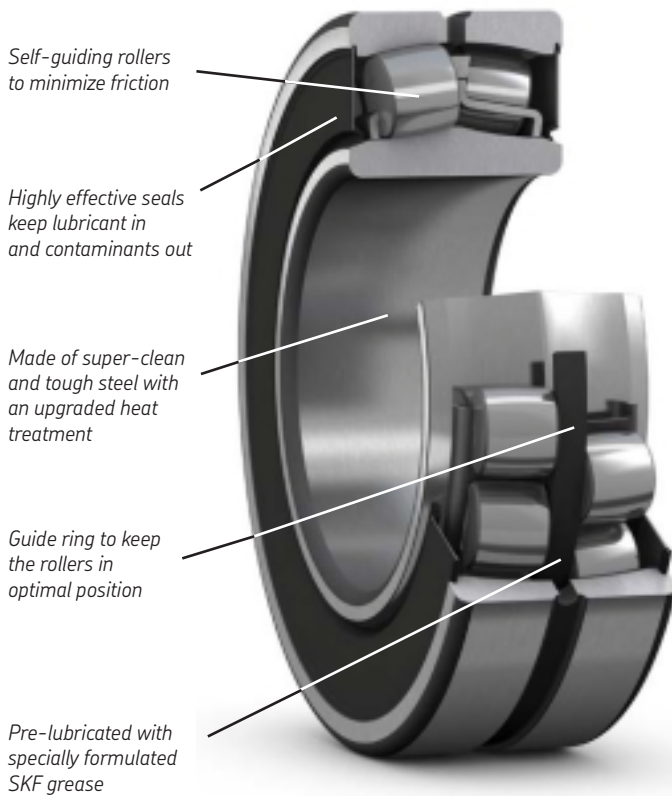

Your choice of bearings has a direct effect on your bottom line. SKF makes that choice easy with a range of bearings that deliver optimal performance for virtually any application.

Sealed SKF Explorer spherical roller bearings can significantly increase bearing service life in contaminated environments. These bearings are pre-lubricated with a specially formulated bearing grease and sealed with highly effective contact seals. The seals protect the bearing and lubricant from contaminants that might otherwise cause premature bearing failure.

In many applications, these bearings can be considered lubricated for the life of the bearing. By eliminating or extending relubrication intervals, these bearings can significantly reduce the cost to purchase, apply and dispose of grease. Reduced maintenance costs can, in many cases, substantially reduce the total cost of ownership of an application.

The SKF range of sealed spherical roller bearings is the widest among all manufacturers.

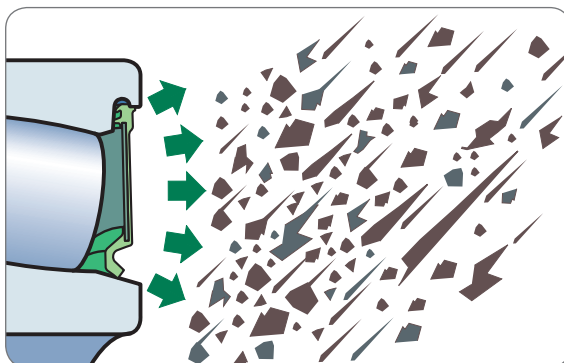

*The highly effective contact seals keep contaminants out*

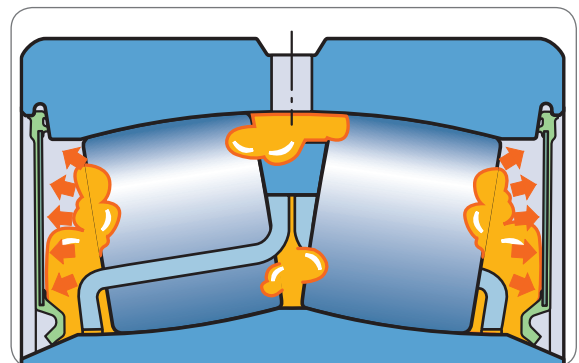

*The seals keep the lubricant inside of the bearing, extending relubrication intervals*

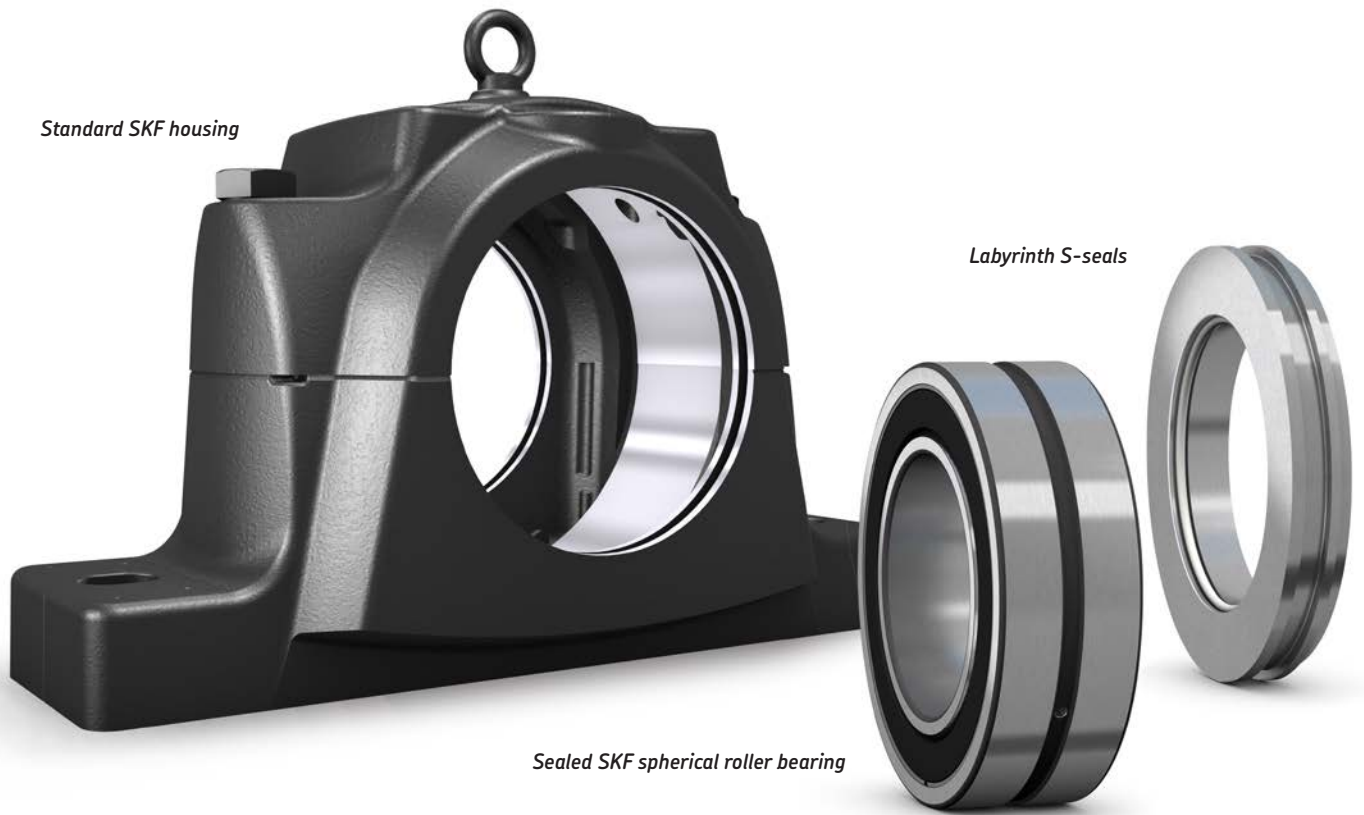

## The SKF Three-Barrier Solution

For the harshest operating environments, SKF recommends the three-barrier solution, which consists of a standard SKF housing, a sealed SKF spherical roller bearing and labyrinth seals. This cost-effective bundle of products can extend bearing service life without complicated and expensive sealing arrangements. By protecting the bearing during assembly and operation, the system provides optimum bearing life while requiring minimal maintenance.

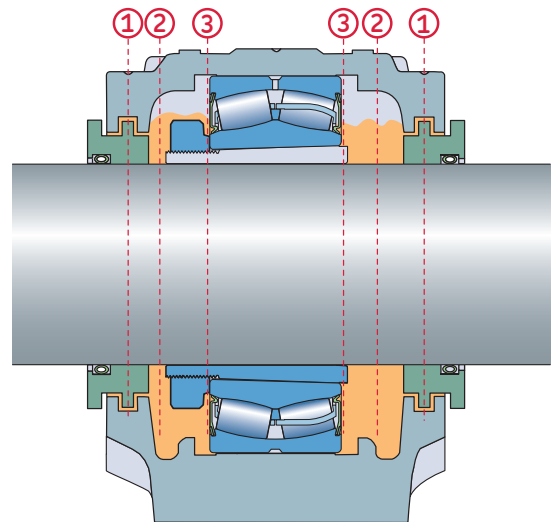

- 1 SKF labyrinth S-seals – standard, cost-effective housing seals are proven to prevent the ingress of contaminants.
- 2 Grease – SKF recommends filling the housing with biodegradable SKF LGGB2 grease to act as a contamination barrier.
- 3 Integral bearing seals – the highly effective seals of sealed SKF spherical roller bearings help keep lubricant in and contaminants out of the bearing.

## The Power of Knowledge Engineering

Combining products, people, and application-specific knowledge, SKF delivers innovative solutions to equipment manufacturers and production facilities in every major industry worldwide. Having expertise in multiple competence areas supports SKF Life Cycle Management, a proven approach to improving equipment reliability, optimizing operational and energy efficiency and reducing total cost of ownership.

These competence areas include bearings and units, seals, lubrication systems, mechatronics, and a wide range of services, from 3-D computer modelling to cloud-based condition monitoring and asset management services.

SKF's global footprint provides SKF customers with uniform quality standards and worldwide product availability. Our local presence provides direct access to the experience, knowledge and ingenuity of SKF people.



## SKF BeyondZero

SKF BeyondZero is more than our climate strategy for a sustainable environment: it is our mantra; a way of thinking, innovating and acting.

For us, SKF BeyondZero means that we will reduce the negative environmental impact from our own operations and at the same time, increase the positive environmental contribution by offering our customers the SKF BeyondZero portfolio of

products and services with enhanced environmental performance characteristics.

For inclusion in the SKF BeyondZero portfolio, a product, service or solution must deliver significant environmental benefits without serious environmental trade-offs.

SKF Energy Efficient (E2) spherical roller bearings are included in the SKF BeyondZero portfolio because the bearing frictional moment is reduced by at least 30%.

For more information about SKF Explorer bearings,  
see your SKF representative or visit [skf.com/srb](http://skf.com/srb)

© SKF, SKF Explorer and BeyondZero are registered trademarks of the SKF Group.

™ SKF EnCompass is a trademark of the SKF Group.

© SKF Group 2015

The contents of this publication are the copyright of the publisher and may not be reproduced (even extracts) unless prior written permission is granted. Every care has been taken to ensure the accuracy of the information contained in this publication but no liability can be accepted for any loss or damage whether direct, indirect or consequential arising out of the use of the information contained herein.

PUB BU/P2 15501/1 EN · June 2015

Certain image(s) used under license from Shutterstock.com

