

PRODUCT NOTE

# RPM AC CTDD motors

## for air cooled heat exchangers



**BALDOR • RELIANCE**

Air cooled heat exchangers for process cooling are a challenging application. While the heat exchanger itself is a simple device, the requirement to maintain a high operational tempo with minimum downtime to support continuously operating industrial processes is often difficult to meet with conventional motor and power transmission technology. Whether using belts or gearboxes, conventional motors and power transmission equipment require regular maintenance several times a year. Belts must be periodically tightened or replaced, and gearboxes require monthly oil checks and semi-annual oil changes. Conventional 'high speed' motors also require relubrication every couple of months.

Baldor-Reliance RPM AC motors allow exchanger fans to be mounted directly to the motor shaft, eliminating the need for speed reduction devices such as pulleys, belts, and gearboxes. The motor's low operating speed also means that relubrication cycles can be extended to an annual basis requiring only a brief shutdown once per year to apply grease to the bearings.

Baldor-Reliance® RPM AC CTDD (Cooling Tower Direct Drive) motors are a new approach to maintaining continuous availability of air-cooled heat exchangers for process cooling. By utilizing optimum pole winding technology, RPM AC CTDD motors operate at very low speeds with very high torque outputs.

RPM AC CTDD motors also improve system efficiency. Not only are the losses from belts or gearboxes eliminated, the motor itself is very efficient. By utilizing a permanent magnet rotor, the direct drive motor eliminates rotor losses and offers increased efficiency.



## RPM AC CTDD motors

for air cooled heat exchangers

### Comparison of a 10 bank ACHE to a single bank direct drive ACHE

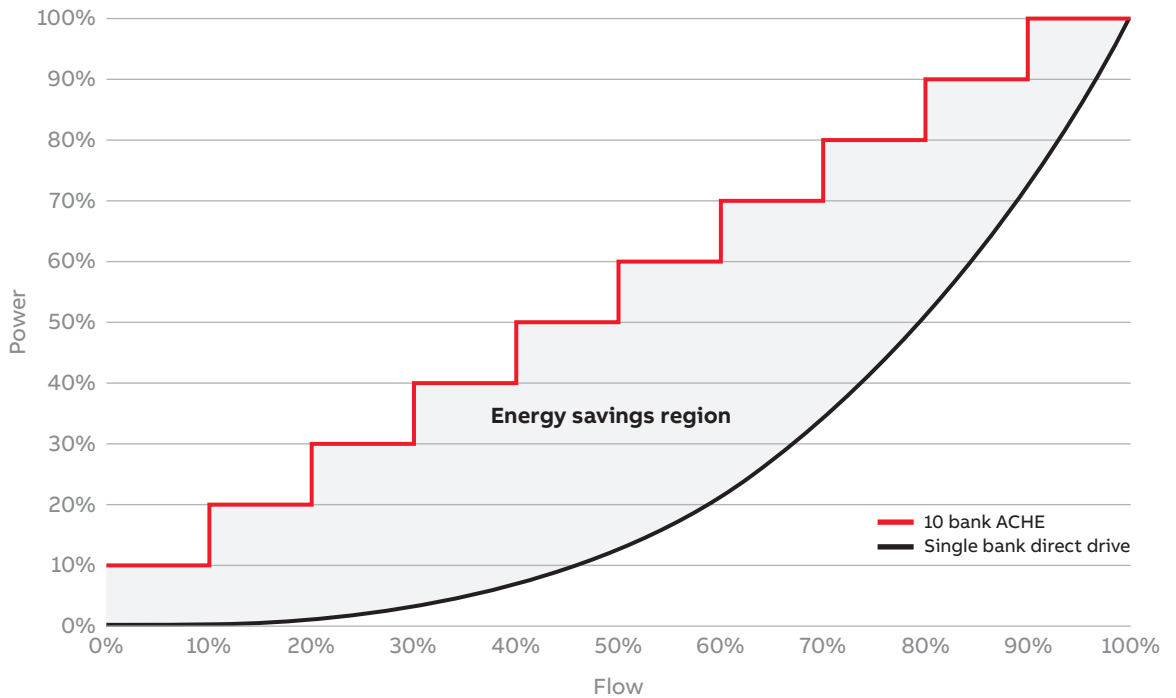

Cooling air flow	50%	60%	70%	80%	90%	100%
Power: 10 bank belt drive	50%	60%	70%	80%	90%	100%
Power: Single bank direct drive	13%	22%	34%	51%	73%	100%

The variable frequency drive used to power the direct drive motor offers the opportunity to regulate fan speed to maintain specific process cooling requirements. Rather than running the fan at full speed when only partial cooling is needed, the CTDD motor can run at any speed to offer only the cooling that is needed. Due to the nature of fans, running reduced speed offers proportionally reduced cooling air flow but also offers exponentially reduced power consumption. Thus, variable speed fan operation can offer immense opportunity for power savings and greenhouse gas reductions.



## RPM AC CTDD motors

for air cooled heat exchangers

Baldor-Reliance CTDD motors are built to last. Utilizing totally enclosed construction, the CTDD motor has an IP66 ingress protection rating. The drive end of the motor utilizes an Inpro/Seal with shaft grounding brush, and the motor frame is painted with a rugged C3 paint system to protect against even the harshest industrial environments. The motor winding utilizes a high temperature Class H insulation system and a robust VPI varnish treatment. We offer a five-year warranty for all CTDD motors except the FL5800 framed motors, which has a three-year warranty.

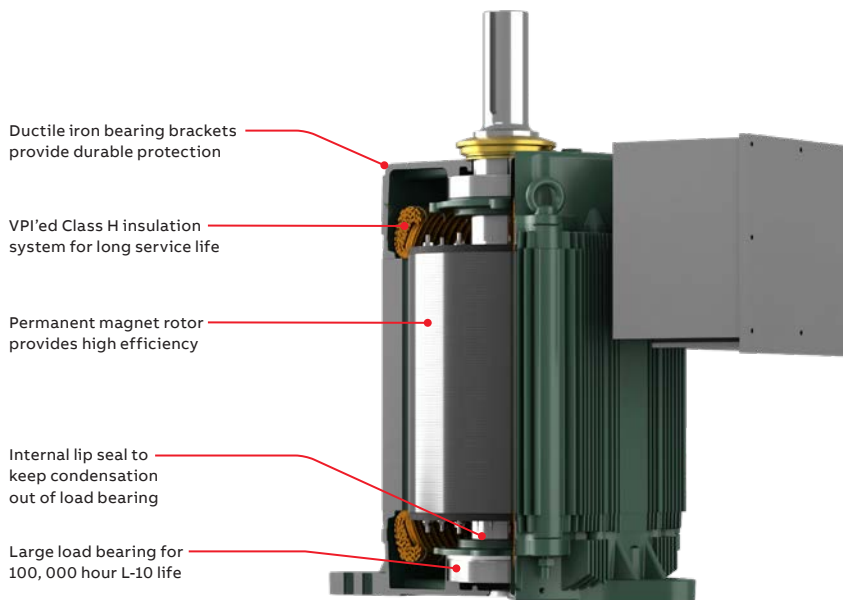
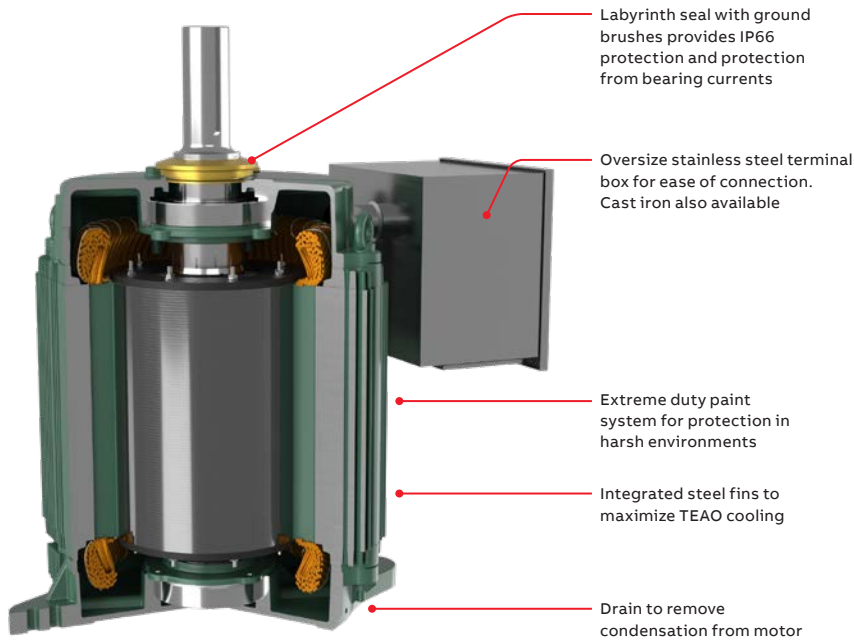

---

ABB Motors and Mechanical Inc.  
5711 R.S. Boreham, Jr. Street  
Fort Smith, AR 72901  
Ph: 1.479.646.4711

**[new.abb.com/motors-generators](http://new.abb.com/motors-generators)**