

We pioneer motion

FAG SAFD200 Series Housings

Performance, durability and versatility – encased in high-strength ductile iron – for shaft sizes ranging from 3” to 9 - 9/16”

The latest addition to Schaeffler’s lineup of industry-leading split pillow block bearing housings, the all-new FAG SAFD200 series has been specifically engineered to accommodate cylindrical-bore spherical roller bearings with a stepped (shouldered) or sleeved shaft. Perfect for higher load-carrying applications affected by high impact shocks and vibrations as well as extremely cold operating environments, Schaeffler’s FAG SAFD200 series housings are cast in high-quality ductile iron. Designed with two different shaft size openings and the associated seals, all FAG SAFD200 series housings feature a universal design and come complete with radial labyrinth (LER) seals, stabilizing rings and end covers. Upgradeable to Schaeffler’s popular FAG SuperTAC II™ taconite seals for highly contaminated operating environments. Note: Bearing, lock nut and lock washer must be ordered separately.

FAG SAFD200 Series Housings: Available in ductile iron for SAFD216 through SAFD244 sizes

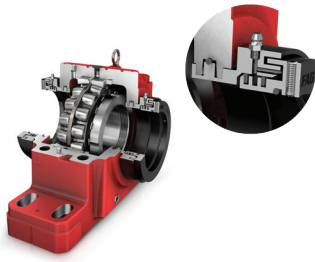

Next-Generation SAF Housings

Completely redesigned, Schaeffler's new generation of SAF housings feature numerous benefits that ensure optimal bearing performance in a broad range of applications:

- Versatile: Designed for standard/unsplit Spherical Roller Bearings (series 222..). Available in ductile cast iron only.
- Precise mounting assured: Markings clearly identify the center of the housing, while machined locating faces enable quick and accurate positioning
- Universal design: Includes LER seals, stabilizing rings and end cover

X-life® Spherical Roller Bearings series 222..

- X-life quality honed raceway surface finishes
- Improved performance under combined load conditions
- Increased dynamic load ratings / higher rating lifetime
- High static load safety factor
- Reduced friction and lower operating temperatures

Lock Nut & Lock Washers

- Used for mounting bearings on cylindrical shafts
- Industry-leading Schaeffler quality

For a comprehensive technical overview of Schaeffler's SAF Series Housings, please refer to our technical publication TPI229

Housing Size	d2 Shaft Diameter	d3 Shaft Diameter	SRB	Lock Nut	Lock Washer
FSAFD216U	3-5/8	3	22216	AN16	W16
SAFD216U	3-5/8	3	22216	AN16	W16
FSAFD217U	3-15/16	3-3/16	22217	AN17	W17
SAFD217U	3-15/16	3-3/16	22217	AN17	W17
FSAFD218U	4-1/8	3-3/8	22218	AN18	W18
SAFD218U	4-1/8	3-3/8	22218	AN18	W18
FSAFD220U	4-1/2	3-13/16	22220	AN20	W20
SAFD220U	4-1/2	3-13/16	22220	AN20	W20
SAFD222U	4-7/8	4-3/16	22222	AN22	W22
SAFD224U	5-5/16	4-9/16	22224	AN24	W24
SAFD226U	5-7/8	4-15/16	22226	AN26	W26
SAFD228U	6-1/4	5-5/16	22228	AN28	W28
SAFD230U	6-5/8	5-3/4	22230	AN30	W30
SAFD232U	7	6-1/16	22232	AN32	W32
SAFD234U	7-7/16	6-7/16	22234	AN34	W34
SAFD236U	7-13/16	6-7/8	22236	AN36	W36
SAFD238U	8-3/8	7-1/4	22238	AN38	W38
SAFD240U	8-3/4	7-5/8	22240	AN40	W40
SAFD244U	9-9/16	8-5/16	22244	N44	W44

shaft dimensions shown in inches

SAFD200 Universal / Standard

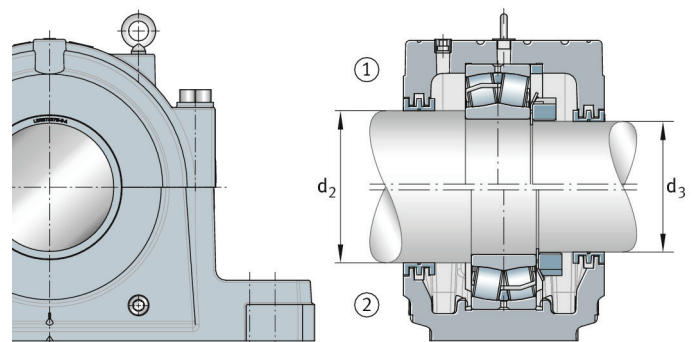

- ① locating configuration
- ② non-locating configuration



Schaeffler Group USA Inc.
308 Springhill Farm Road • Fort Mill, SC 29715
www.schaeffler.us • info.us@schaeffler.com