



TSUBAKI KABELSCHLEPP



TKHP[®] SERIES

High-Performance cable carriers for
long travel lengths and high additional loads

TKHP® SERIES

New high-performance cable carriers in solid design in two sizes for extremely long travel distances and high additional loads with integrated rollers

Our new TKHP® series is a reliable and efficient cable routing for high-performance applications with travel lengths up to 1500 meters in rough conditions, such as port cranes or the transport of bulk materials. It can absorb a high level of force, is highly durable and dirt-resistant.

The TKHP® is available in three versions: gliding, rolling (R), and rolling with roller damping (RSD). With an inner height of 58 mm or 92 mm and variable widths in 1-mm increments, the series can be flexibly adapted to virtually any installation situation.

The performance of the TKHP® is based on a clever design concept: The symmetrically positioned longitudinal axis ensures optimum force transmission and a reduction of the torques occurring in the cable carrier turning point. The encapsulated stroke system, the dirt-resistant, self-cleaning outer contour and the reinforced pin hole connection meet the highest requirements in terms of robustness. The solid sidebands with bolted chain links and a special double-fork and tab design also support the sturdiness of the TKHP®.

The new TKHP® series places a special focus on durability. We optimize this with the right materials, an intelligent cable carrier design and a sustainable service concept for the product. The design aspects include wear-free damping in the stroke system and aluminum opening stays that are gentle on the cables and resistant to seawater.

Thanks to the polygon-optimized outer contour, an integrated brake, and the virtually gap-free running faces, the cable carriers are particularly quiet. The small pitches of 85 or 90 mm also support the lower noise emissions. The smooth running is also promoted by the innovative roller damping, which lowers the mechanical load when moves over the rollers by up to 50 %.

The "grip grooves" on the running faces are another clever detail. These ensure that the rollers have optimum grip even in environments with fine dust. This makes one-sided wear caused by blocked rollers a thing of the past.

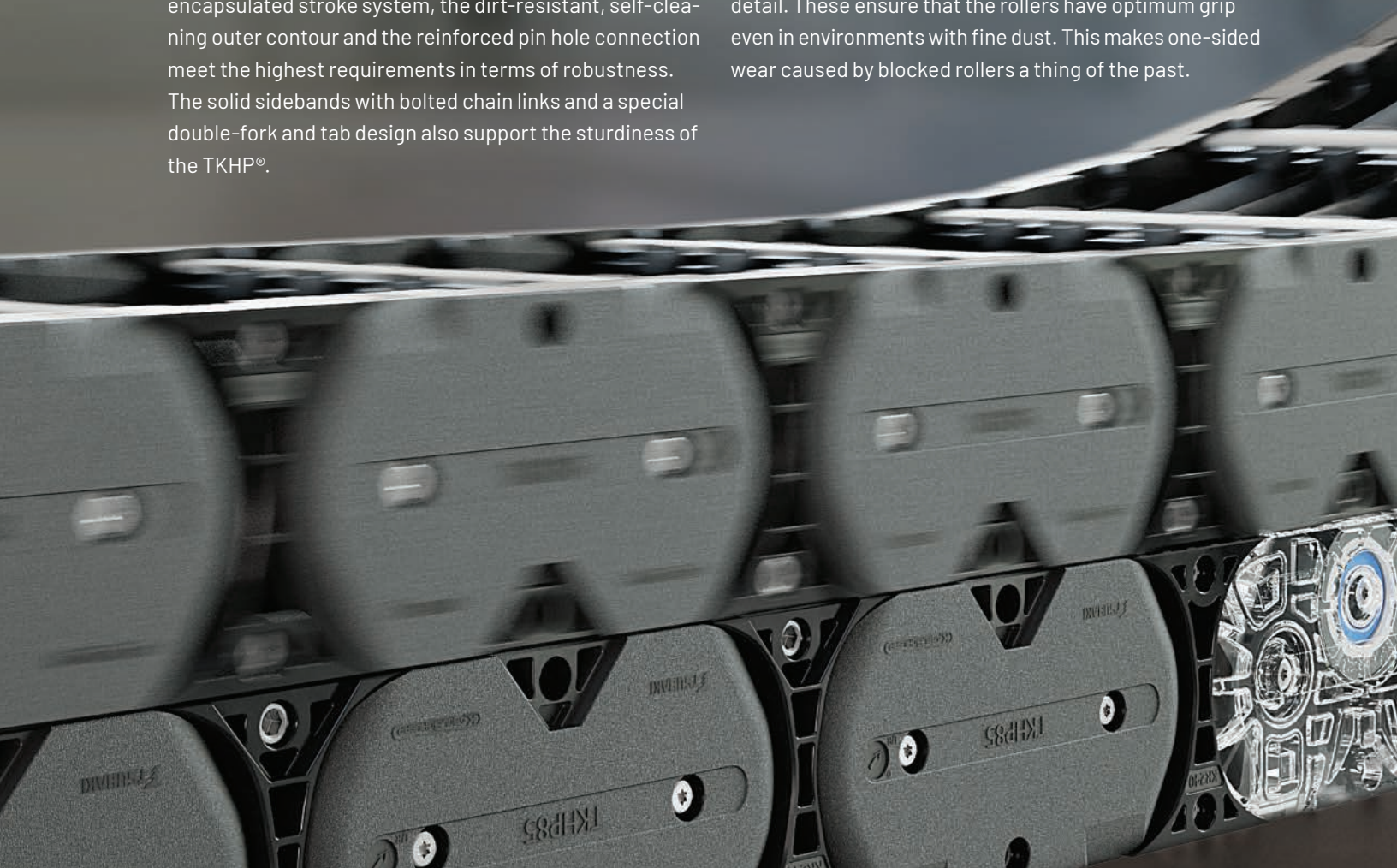

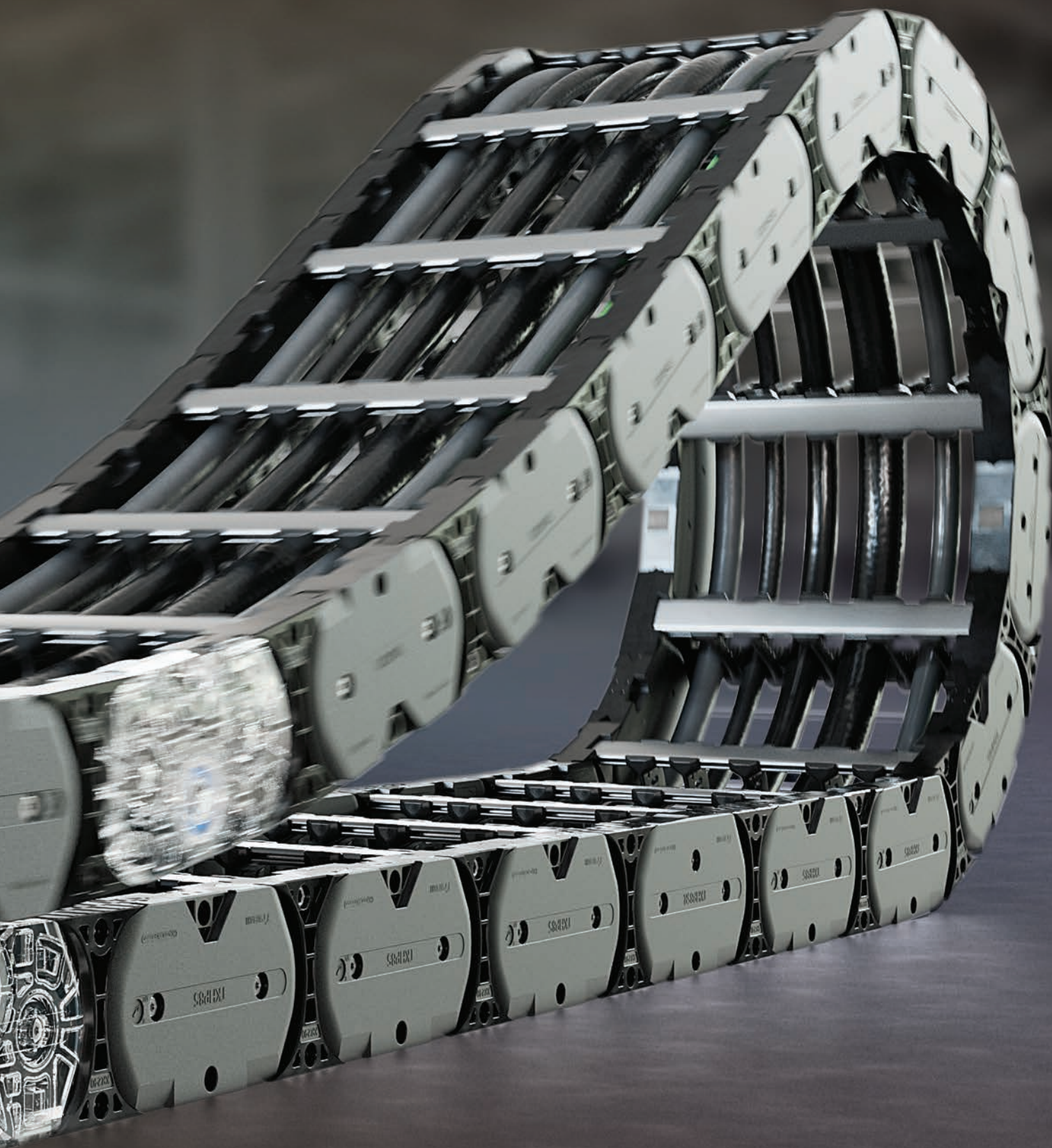

TKHP® SERIES

Cable carriers from the new TKHP® series from TSUBAKI KABELSCHLEPP combine everything that an application in a rough environment needs: maximum sturdiness, minimum maintenance effort, and an extremely long service life. The cable carriers are available in the specifications 85 and 90 with two different inner heights – gliding, rolling, or with innovative roller damping.

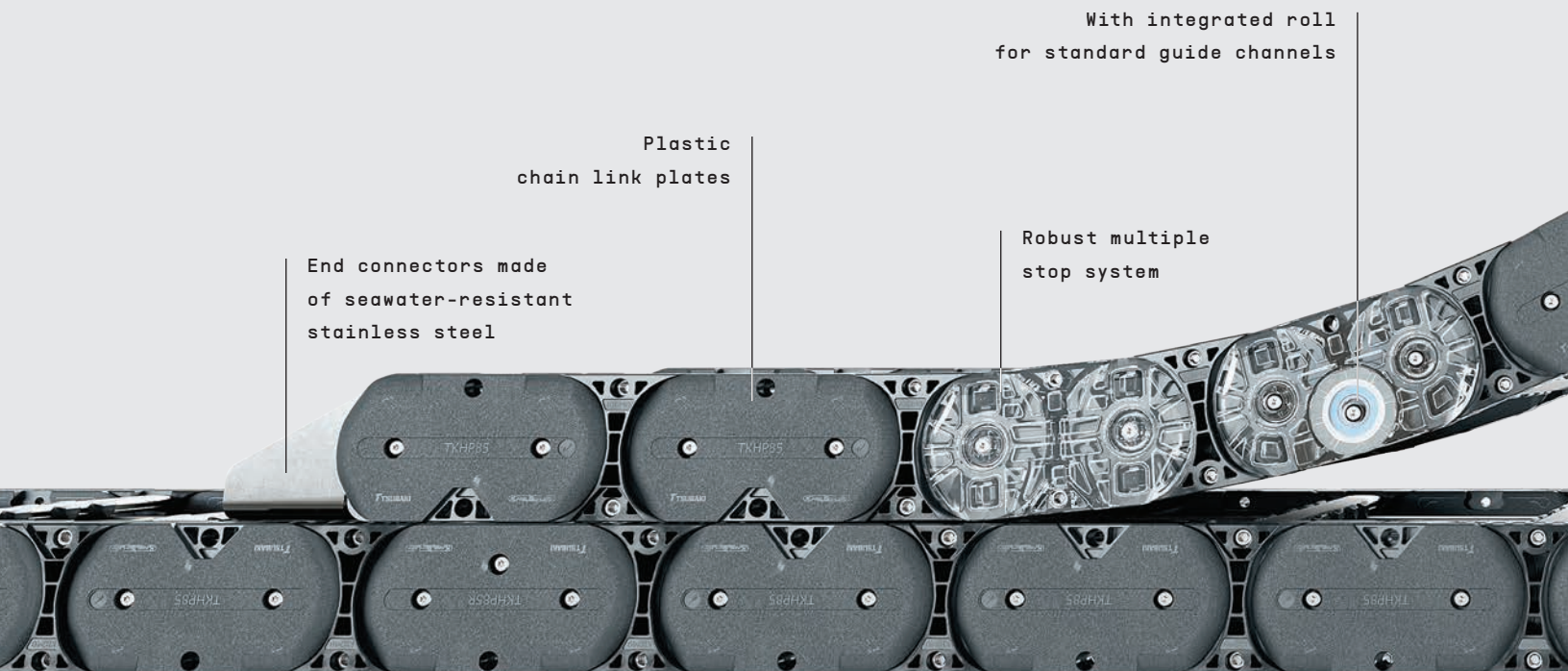

The assigned values are average values. Depending on the specific application, the maximum values may differ significantly. For detailed information please contact us.

Features

- » High-performance cable carriers in three versions:
 - TKHP85/90
 - TKHP85/90-R with rollers
 - TKHP85/90-RSD with rollers and roller damping
- » Massive, enclosed, stain-repellend stop system
- » Massive sidebands through robust double fork-bracket-construction
- » Sidebands easy to assemble
- » Reinforced symmetrically arranged pin bore connection for better force transmission
- » Integrated noise damping
- » Quick and easy opening to the inside or outside for cable laying
- » Soil-resistant outer contour
- » Easy change of components
- » Easy replacement of chain links within the cable carrier
- » Maintenance-free
- » Linear force curve in the sideband
- » Quiet and low-wear operating through polygon-optimized contour and radii
- » Reduce drive power through less friction
- » Bolted version
- » Standard stay arrangement on every 2nd chain link (HS: half-stayed)

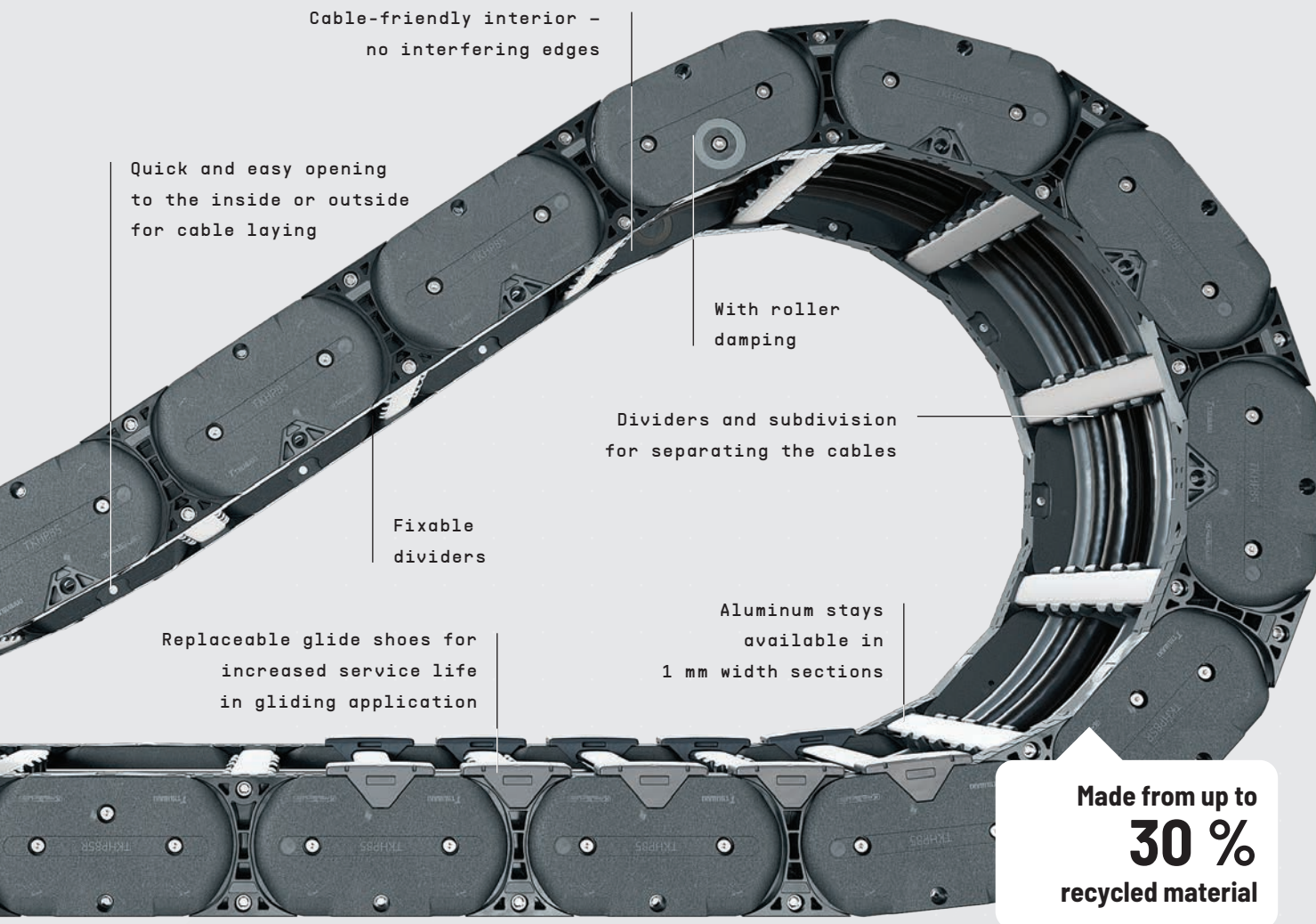

Inner width in 1 mm increments



Long travel length



Roller chain



Opens inward/outward



High additional load



Sliding dividers



Fixable dividers



Height separation possible



Very smooth running of the roller system due to almost continuous running surface.



A non-slip structure on the running surface prevents one-sided roller wear after a standstill.



Roller chain for travel distances up to 1200 m.



RSD version with roller damping to reduce noise and wear by up to 50 %.

TKHP85 / TKHP85-R / TKHP85-RSD

Aluminum stay RMF – Frame stay solid with optional fixing profile

- » Aluminum profile bars for heavy loads and large cable carrier widths. Easy threaded connection.
- » Outside/inside: Threaded joint easy to release
- » Stay arrangement on every 2nd chain link (HS: half-stayed)

Inner height h_i	Outer height h_o	Inner widths B_i	Outer widths B_o	B_i grid	Pitch t	Bending radii KR	Inner distribution
58 mm	84 / 84.5 mm	100-800 mm	154-854 mm	1 mm	85 mm	240-400 mm	TS0 / TS1

TKHP85

Compact and lightweight high-performance cable carrier for unsupported and gliding applications



Additional load up to 50 kg/m	Travel speed up to 5 m/s
Travel length up to 200 m	Travel acceleration up to 20 m/s ²

TKHP85-R / TKHP85-RSD

Compact and lightweight high-performance cable carrier with rollers/roller damping for very long travel distances



Additional load up to 50 kg/m	Travel speed up to 5 m/s
Travel length up to 1200 m	Travel acceleration up to 50 m/s ²

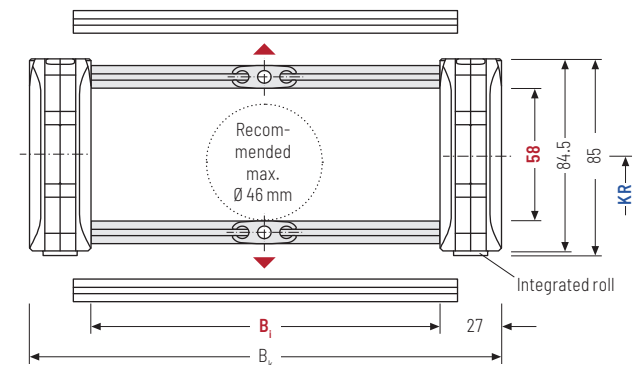
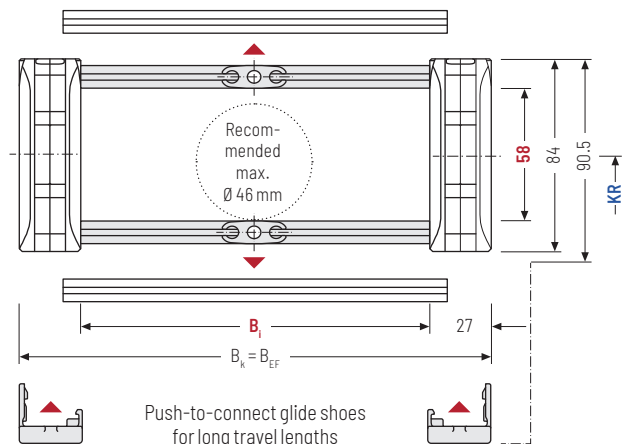

End connectors – steel

The connection variants on the fixed point and on the driver can be combined and changed later on, if necessary.

Connection point

- F** fixed point
- M** driver

Connecting surface

- I** connecting surface inside
- A** connecting surface outside

Connection type

- A** threaded joint outside (standard)
- I** threaded joint inside

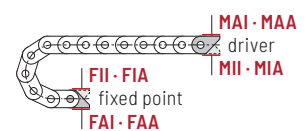

TKHP90 / TKHP90-R / TKHP90-RSD

Aluminum stay RMF – Frame stay solid with optional fixing profile





- » Aluminum profile bars for heavy loads and large cable carrier widths. Easy threaded connection.
- » Stay arrangement on every 2nd chain link (HS: half-stayed)
- » Outside/inside: Threaded joint easy to release

Inner height h_i	Outer height h_o	Inner widths B_i	Outer widths B_k	B_i -grid	Pitch t	Bending radii KR	Inner distribution
92 mm	117 / 117.5 mm	100-800 mm	170-870 mm	1 mm	90 mm	250-500 mm	TS0 / TS1

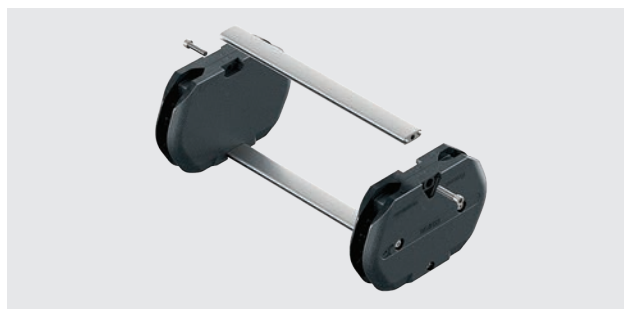
TKHP90

High-performance cable carrier for unsupported and gliding applications





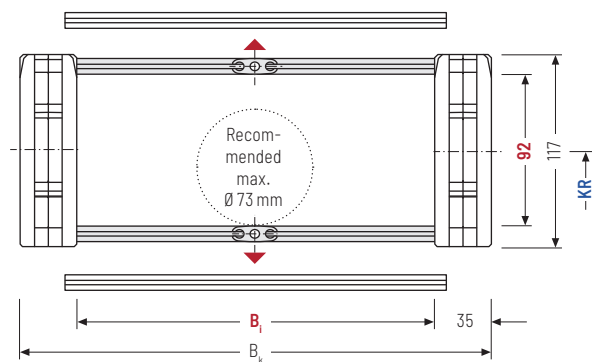

 Additional load	up to 100 kg/m	 Travel speed	up to 8 m/s
 Travel length	up to 200 m	 Travel acceleration	up to 20 m/s ²

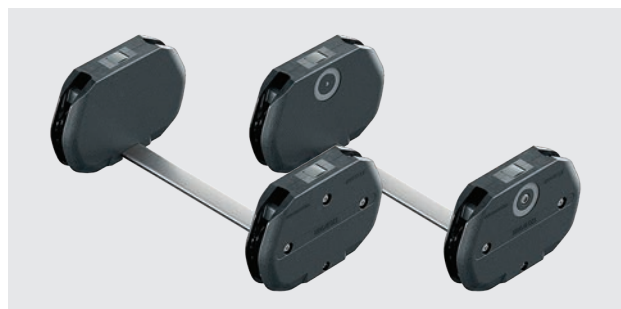

TKHP90-R / TKHP90-RSD

High-performance cable carrier with rollers/roller damping for very long travel distances



 Additional load	up to 100 kg/m	 Travel speed	up to 10 m/s
 Travel length	up to 1500 m	 Travel acceleration	up to 50 m/s ²

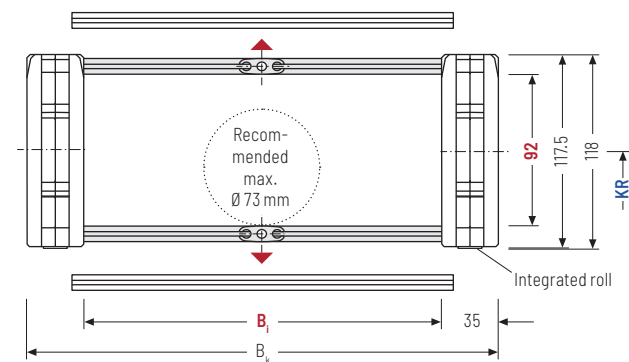

End connectors – steel

The connection variants on the fixed point and on the driver can be combined and changed later on, if necessary.

Connection point

- F** fixed point
- M** driver

Connecting surface

- I** connecting surface inside
- A** connecting surface outside

Connection type

- A** threaded joint outside (standard)
- I** threaded joint inside

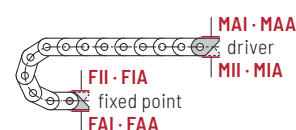

STANDARDIZED MONITORING SYSTEM TKCMS FLOATING MOVING DEVICE TKFMD

SAFETY DEVICES FOR CRANES AND LONG TRAVEL APPLICATIONS

Better safe than sorry – this is also true for cable carrier systems. With the two solutions “Standardized Monitoring System” and “Floating Moving Device” we have two very useful helpers in our portfolio.



Standardized Monitoring System TKCMS

- » Programmable for different tasks
- » Different tasks available
- » Less program effort
- » Different interfaces
- » Standardized top-hat-rail-module
- » Operating system independent
- » Independently programmable

Wear monitoring for cranes

- » Determine and evaluate real-time wear values of glide shoes
- » Operating system independent
- » Easy to retrofit and to install
- » No sensor-cables inside the cable carrier
- » No radio transmission
- » Using standard components
- » Easy access to all sensors
- » Maintenance free
- » Outcoming signal PLC usable
- » Internal data storage

Force monitoring for cranes

- » Usable for automatic emergency stop-system
- » Direct measurement of the push/pull-forces at the moving point
- » Force limits free programmable (lower/upper)
- » Error indication if the limits are exceeded
- » Outcoming signal PLC usable internal
- » Data storage
- » Maintenance free
- » No speed limit

Floating Moving Device TKFMD

- » Compensate horizontal misalignment
- » Misalignment compensation: vertical +/-60 mm
- » Easy installation, less maintenance
- » Roller supported
- » Integrated strain relief system
- » Safe cable guidance
- » Combinable with “Standardized Monitoring System”
- » For M series and TKHP® series

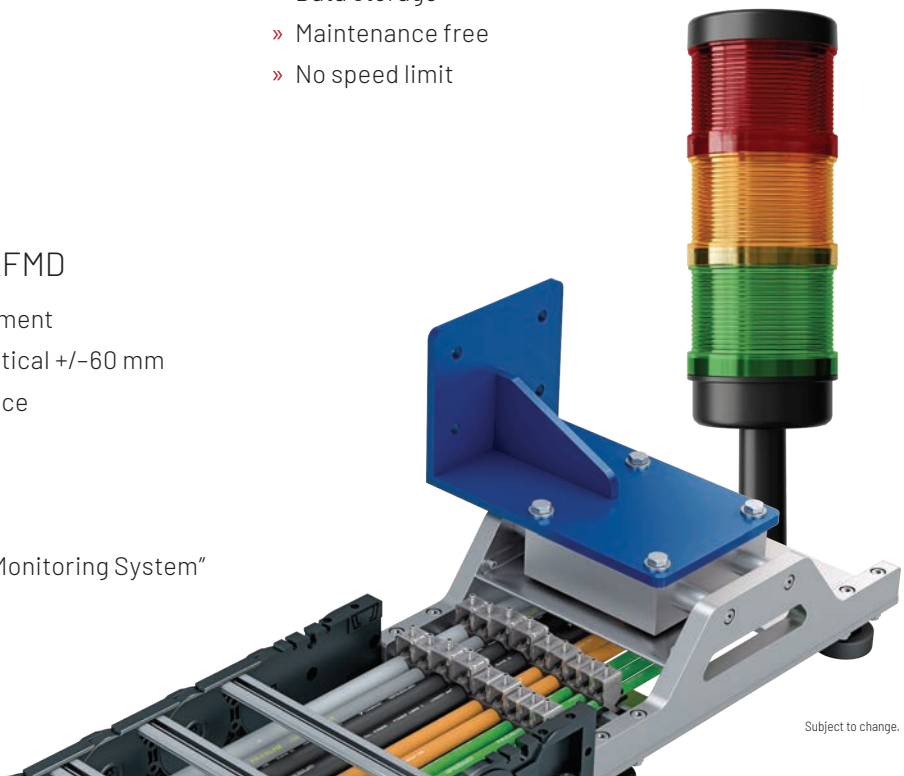

STEEL GUIDE SYSTEM TKSG

GUIDE CHANNELS IN THE MODULAR SYSTEM

Easy-to-install modular system with optimized design for long travel lengths in standard lengths of 1000 and 2000 mm. Available in galvanized sheet steel or stainless steel.

Features

- » Especially suitable for cranes and applications with long travel lengths
- » Simple design for short installation times
- » No accumulation of dirt through open construction
- » Fast and easy installation thanks to pre-assembled sidebands and channel brackets
- » Complete system for screw fitting
- » All components without welds

Type	Outer height h_{KA}	Inner width b_1	Outer width B_{KA}	Sheet metal thickness
TKHP85	209 mm	$B_k + 6$ mm	$B_k + 136$ mm	2 mm
TKHP85-R + RSD				
TKHP90	258 mm	$B_k + 6$ mm	$B_k + 136$ mm	2 mm
TKHP90-R + RSD				



ALU GUIDE SYSTEM TKAL

ALUMINIUM GUIDE CHANNELS IN THE MODULAR SYSTEM

Lightweight modular system for high speeds with many mounting options/mounting sets in standard lengths of 1000 and 2000 mm.

Features

- » Safe operation on long travel length
- » Seawater resistant
- » Twin channel connectors for parallel arrangement of several channels
- » Slide and roller support made of high quality plastic
- » Standard and Heavy Duty Version
- » Variable fixation in standard stainless steel
- » UMB mounting kit for assembly of the cable carrier

Type	Outer height h_{KA}	Inner width b_1	Outer width B_{KA}
TKHP85	254 mm	$B_k + 6$ mm	$B_k + 40.6$ mm
TKHP85-R + RSD			
TKHP90	274 mm	$B_k + 6$ mm	$B_k + 40.6$ mm
TKHP90-R + RSD			

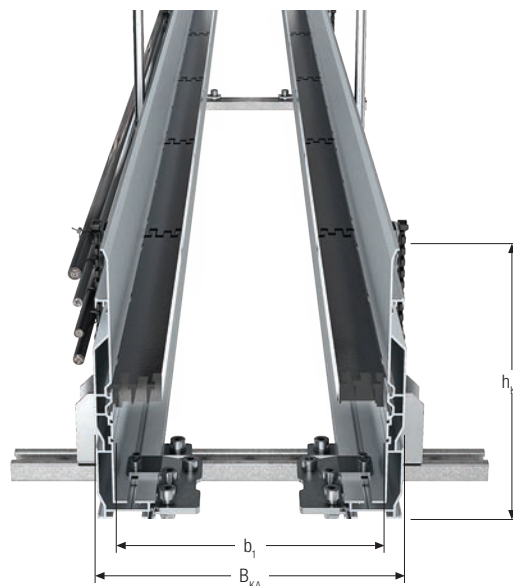

TRAXLINE® CABLES FOR CABLE CARRIERS

Our Series 700 and 1000 meets the highest quality standards to ensure the continuous availability of your application. The TRAXLINE® product range offers high-flex cables that are extremely durable and especially designed for being used in cable carriers. A main feature is their tested and proven operational reliability, which meets the applicable standards and directives. Competent, objective-driven system consultation and a global onsite service are part of our ongoing commitment to technical and commercial optimization.

High Flexdesign PUR Cables – 700 Series

Developed for

- » Long travel length applications
- » -35 °C to +90 °C
- » Outdoor/indoor
- » Offshore/onshore
- » Very high electrical voltages
- » Small bend radii
- » High speed (up to 50 m/s)
- » High acceleration (up to 50 m/s²)

Properties

- » High flex design
- » Side pressure strength
- » Seawater-resistant
- » Ozone-resistant
- » UV-stable
- » Crude oil resistant
- » Flame-retardant
- » **CE**



- » Cut resistant
- » Halogen-free
- » Silicone-free
- » CFC-free
- » REACH/RoHS II conform
- » Metermarked
- » MUD resistant

Top Flexdesign TPE Cables – 1000 Series

Developed for

- » Heavy load and long travel length
- » -40 °C to +90 °C
- » Crane and conveyor equipment
- » Systems, mechanical and crane engineering
- » Clean room duties
- » Limited space solutions
- » Permafrost using
- » Outdoor applications

Premium properties

- » Low-capacitive
- » Top flexdesign
- » Oil-resistant
- » UV-resistant
- » REACH/RoHS II-conform
- » Halogen-free
- » Microbe resistant
- » Metermarked
- » CFC-free
- » Silicone-free
- » Spark tested 10 kV
- » Ozone-resistant
- » Hydrolysis durable
- » Test voltage 4 kV
- » **CE**

Technical details

- » Shielded continuous bending top FLEXdesign TPE power cables
- » TPE inner jacket
- » Special shielding with 85 % coverage
- » Top FLEXdesign copper wires
- » KS-Special compound core insulation
- » Outer jacket color: black



CUT COSTS WITH TOTALTRAX® COMPLETE CABLE CARRIER SYSTEMS

Use our know-how. Working closely with you, our experienced system specialists can provide pre-sale support, including planning and design services through post sales service and support.

Our system experts work with you to develop the technical solution as a reliable assembly for your product. Only one contact person for the complete system. All components match each other perfectly, including your cable carriers, electrical cables, hydraulic and pneumatic hoses as well as connectors. You'll receive

the complete system in one delivery, with guarantee certificate if desired – in short: TOTALTRAX®. Reduce your storage costs for cable and hose carriers, cables and connectors with TOTALTRAX®. We supply all components Just-In-Time to your production facility or directly to the installation site.

EFFICIENT DESIGN ENGINEERING – PRECISE AND FAST

OnlineEngineer Configurator for cable carriers

We are continuously investing in providing product-related data online to make your work easier.

Our web-based OnlineEngineer platform with world-wide online access provides a variety of functions to support you with the selection and configuration of products for your application. All necessary technical and calculation information for the individual products from the areas of cable carriers, cables and other accessories are provided on a central, clearly structured platform. Selection of the suitable products is made substantially easier by entering different parameters.

- » Optimal price/performance ratio in the configuration of cable carrier system
- » Time savings through automatic configuration function
- » All information of the cable carrier system is displayed as a glance
- » Online price inquiry to KABELSCHLEPP

CADENAS 3D CAD catalog

CADENAS is an internationally used platform for providing 3D component models in a variety of CAD formats. It includes a large number of renowned companies from mechanical engineering, plant engineering and other industry sectors. We are currently offering CAD models in all standard CAD formats for the entire product portfolio. The database also contains the corresponding models for guide channels and support trays. The catalog is continuously expanded and supplemented.

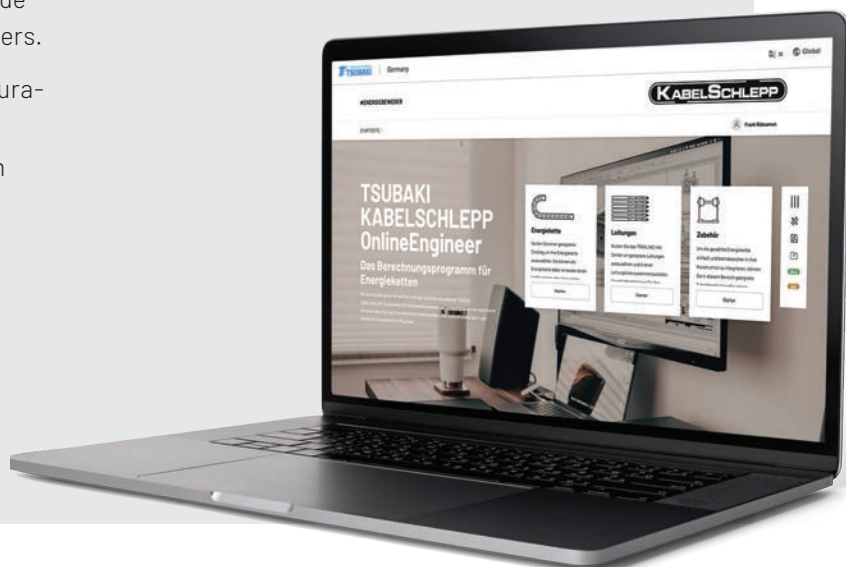

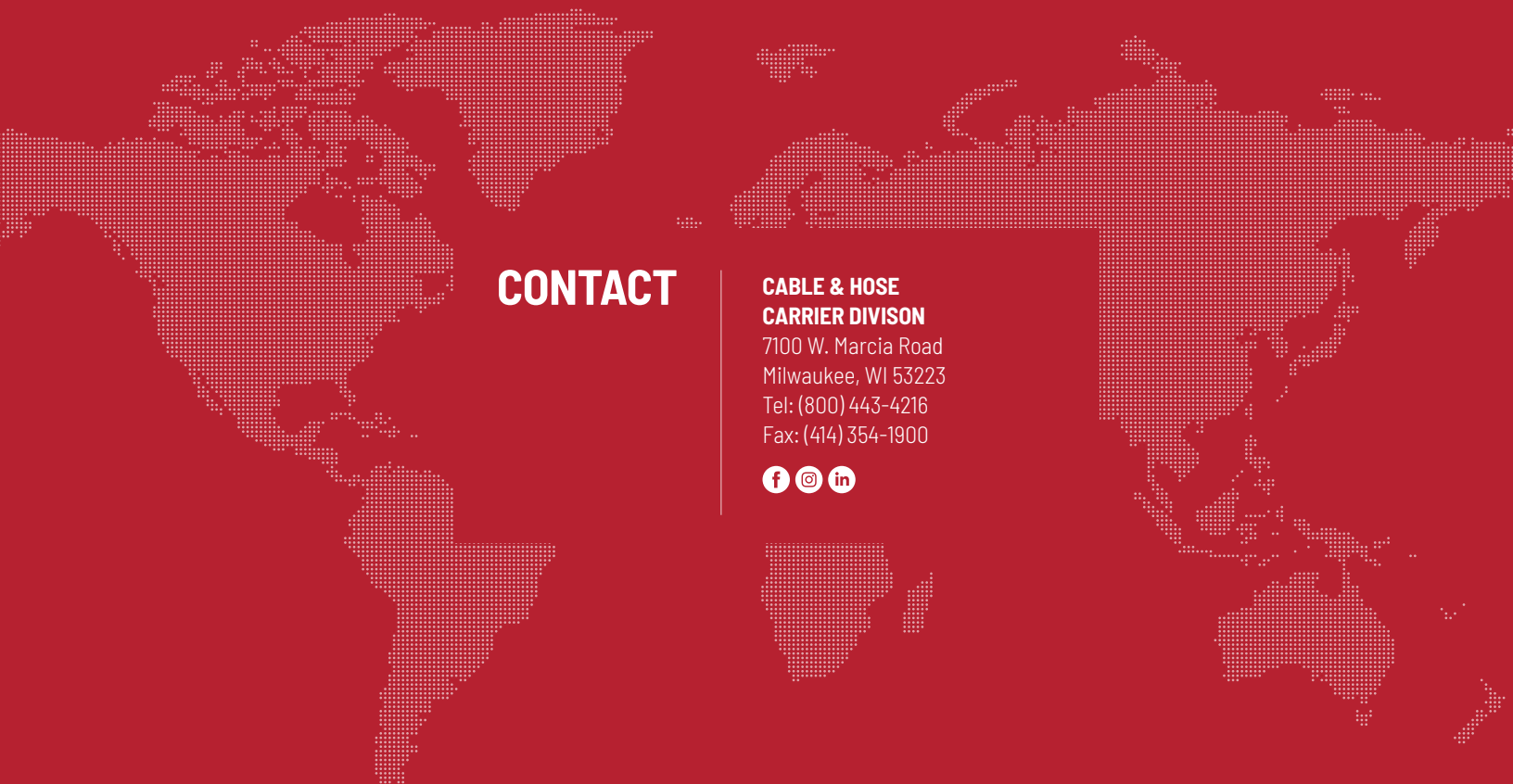

CONTACT

CABLE & HOSE CARRIER DIVISON

7100 W. Marcia Road
Milwaukee, WI 53223
Tel: (800) 443-4216
Fax: (414) 354-1900



Your personal contact



The complete product range under:
tsubaki-kabelschlepp.com